

BOSS LS-2

Line Selector

SPECIFICATIONS

Controls : Pedal Switch, Mode Selector Switch, Level Control Knobs A/B

Indicators : Line Indicators A/B (also serve as a battery check)

Jacks : Input, Output, AC Adaptor In/Out, Send A/B, Return A/B

Input Impedance : 1M Ω

Output Impedance : 1k Ω

Recommended Load Impedance : 10k Ω or greater

Residual Noise : -85dBm or less (IHF-A, Typ)

Power : DC 9V battery (9V), AC Adaptor (PSA Series : option)

Current Draw : 25mA (DC9V)

Dimensions : 70 (W) X 125 (D) X 55 (H) mm / 2-3/4" X 4-15/16" X 2-3/16"

Weight : 410g / 14 oz (including battery)

Accessories : Instructions, Battery S-006P/9V (6F22/9V) X 1, Rubber Feet X 2 (For BCB-6)

Options : AC adaptor PSA-120, 220 or 240,

Battery S-006P/9V, 6AM6/9V (Alkaline), DC cord PCS-20A

* The specifications for this product are subject to change without prior notice.

Copyright © 1991 by BOSS CORPORATION

All rights reserved. No part of this publication may be reproduced in any form without the written permission of BOSS CORPORATION.

BOSS
Products of Roland

Printed in Taiwan '91-10-D3-11C

Instructions

Thank you for purchasing the BOSS LS-2 Line Selector. To make the best use of the unit, please read the instructions carefully.

- The LS-2 provides two separate line-loop outputs.
- The LS-2 features 6 different modes (including effect loop selector and line selector) that enhance its versatility.
- The LS-2 provides individual control over the output level of each line.
- Each line has an indicator, allowing you to easily determine the current state of the unit.
- An AC Adaptor Output Jack is provided to supply power to an external effect unit when an AC adaptor is being used to supply power to the LS-2.

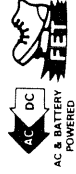
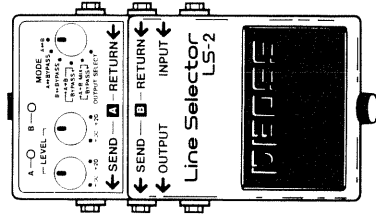

PANEL DESCRIPTION

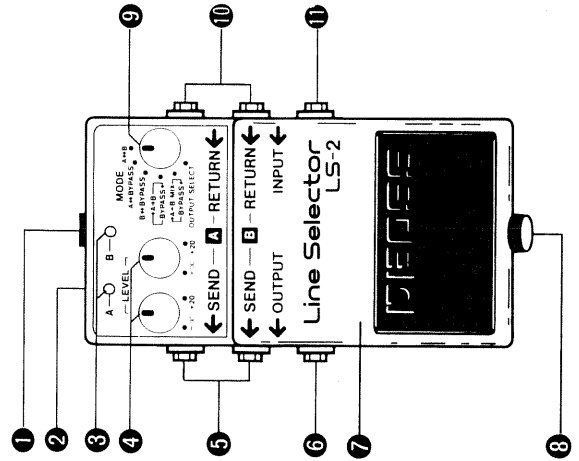

1 AC Adaptor In Jack

Connect an AC adaptor (BOSS PSA-120, 220 or 240 :option) to this jack.

* Use of an AC adaptor eliminates the need for battery.

* Be sure to use the specified AC adaptor (PSA-120, 220 or 240). Using any other adaptor may damage the unit.

2 AC Adaptor Out Jack

When an AC adaptor is being used to power the LS-2, power can also be supplied to another compact effect unit by connecting a paralleled DC cord (PCS-20A : option) to this jack.

* When you are using battery power, the AC Adaptor Out Jack does not function.

* When using the PSA-120, 220 or 240, be sure that the total current draw of the LS-2 and any external effect unit does not exceed 200mA.

3 Line Indicators A/B

The appropriate indicator lights when the corresponding line (A/B) is selected.

4 Level Control Knobs A/B

Each knob controls the output level of the corresponding line (A/B). The output level is variable from $-\infty$ (muted) to +20dB.

* When a knob is set to the center position, the input and output levels are equal.

* These indicators also serve as a battery check. When they become dim (or do not light at all), replace the battery immediately.

5 Send Jacks (A/B)

These jacks send the signals received by the Input Jack when the corresponding line (A/B) is in use.

* Connect an amplifier or other effect unit to this jack.

* Pedal Switch
This switch selects the line to be used.

* Thumb Screw
Loosen this screw to open the pedal for battery replacement. For a detailed explanation, see "Battery Replacement".

* Mode Selector Switch
This switch selects the operating mode. For a detailed explanation, see "MODE DESCRIPTION".

* Return Jacks A/B
These jacks feed the signal from the corresponding line (A/B) into the unit.

* Input Jack
Connect an electric/electronic musical instrument (such as an electric guitar) to this jack.
* Connecting a plug to the Input Jack automatically turns the unit on. Disconnect the plug from the Input Jack when the unit is not in use.

OPERATION

① Select the desired mode.

* Be sure to select an appropriate mode referring to "Mode Description" and "LS-2 Sample Settings".

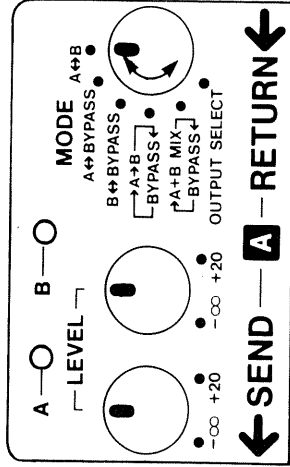

② Connect the relevant units depending on the mode you have selected.

* Before connecting or disconnecting cords, be sure to turn down the volume on the amplifier.

③ Select the desired line by pressing the pedal. Then adjust the output level of each line with the Level Control Knobs.
* The Level Control Knobs may not work depending on how the units are set up.

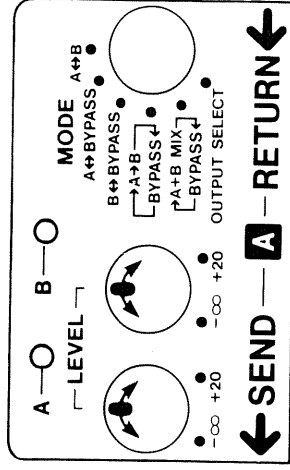

BATTERY REPLACEMENT

① Loosen the thumb screw on the pedal to open it.

② Take out the battery from the battery housing and disconnect the battery snap.

③ Connect a new battery to the battery snap, then replace the battery in to the battery housing.
* Make sure that the polarity of the battery is correct.

④ Push the coil spring into the spring base on the rear of the pedal, then close the pedal.

* Make sure that the snap cord is not caught in the pedal or coil spring.

⑤ Insert the thumb screw into the guide bush hole and firmly tighten the screw.

IMPORTANT NOTES

● To place the LS-2 in the BOSS Carrying Box BCB-6, you need to attach the supplied rubber feet to the BCB-6 shown below.

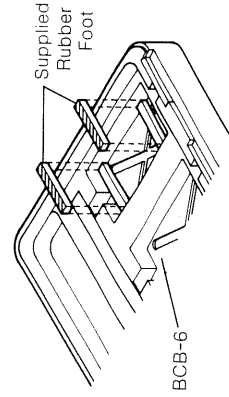

● Remove the battery whenever the unit is not going to be used for an extended period of time.

● When operating solely on a battery, the unit's indicator becomes dim when the battery is depleted. Replace the battery immediately.

● If there is a battery in the unit while an AC adaptor is being used, normal operation will continue should the line voltage be interrupted (power blackout) or the power cord become disconnected.

● Should a malfunction occur (or if you suspect there is a problem) discontinue use immediately. Contact qualified service personnel as soon as possible.

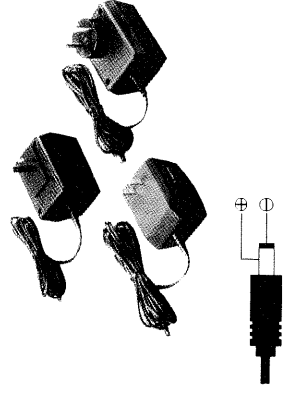

● OUT: 9VDC 200mA

Use one 9-volt battery

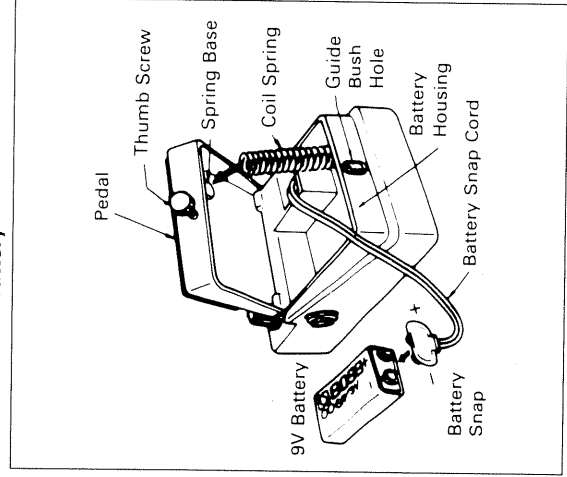

MODE DESCRIPTION

The following describes the LS-2's six operation modes:

* When you change modes, be sure to determine the currently selected line using the Line Indicators.

A ↔ B

Pressing the pedal alternately selects Line A or Line B. This is an ideal setting for using only the line loop function (when bypass output is not required).

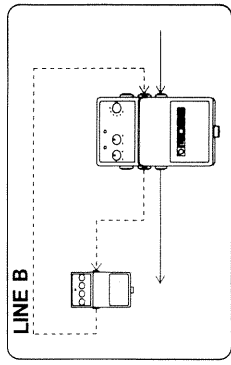
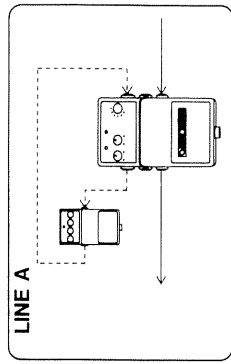

A ↔ BYPASS

Pressing the pedal alternately selects Line A or Bypass.

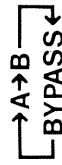
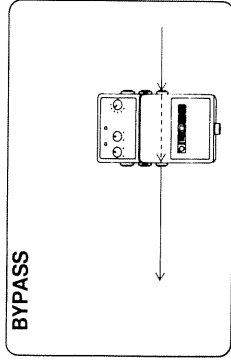
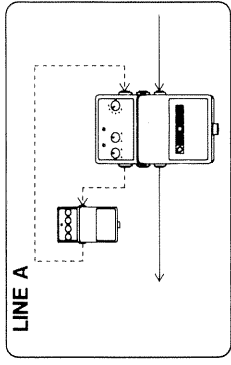

B ↔ BYPASS

Pressing the pedal alternately selects Line B or Bypass.

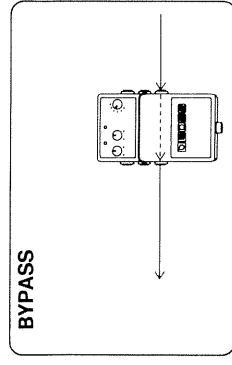
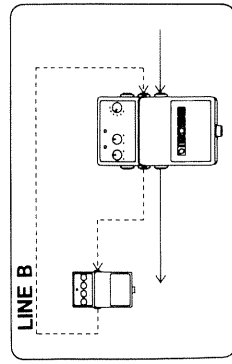

Pressing the pedal repeatedly selects (in sequence) Line A, Line B or Bypass.

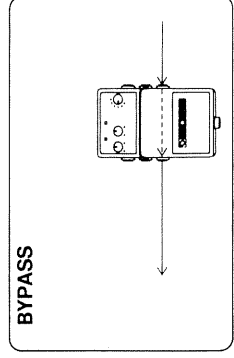
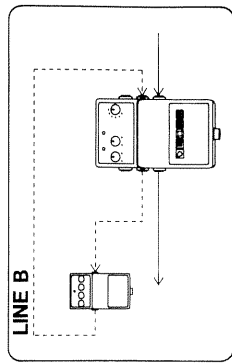
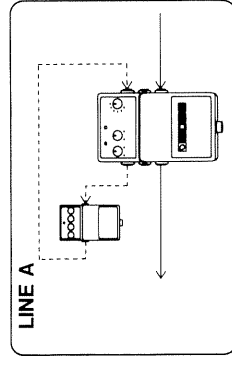

A+B MIX
BYPASS

Pressing the pedal alternately selects Line A + Line B (mixed) or Bypass.

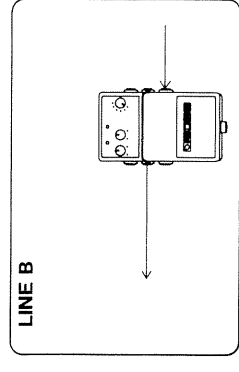
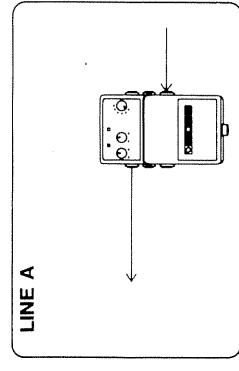
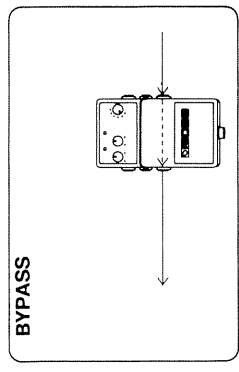
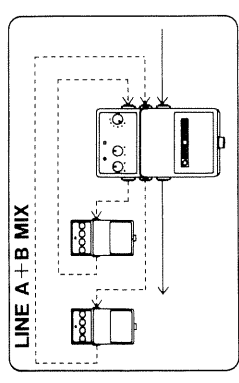

OUTPUT SELECT

Pressing the pedal repeatedly selects (in sequence) Send A, Send B or Output.

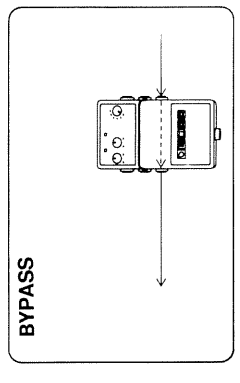

BLOCK DIAGRAM

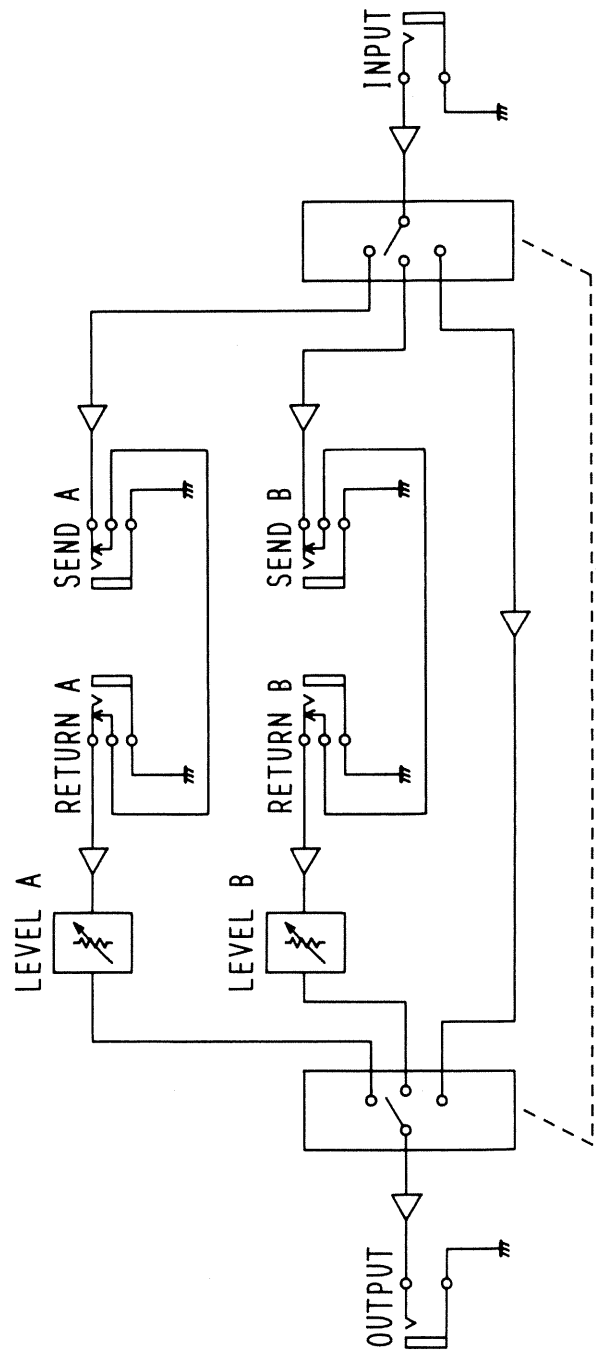

SAMPLE SETTINGS

Setup with the NS-2

You can use the LS-2 with the NS-2 Noise Suppressor. Connect the delay after the NS-2.

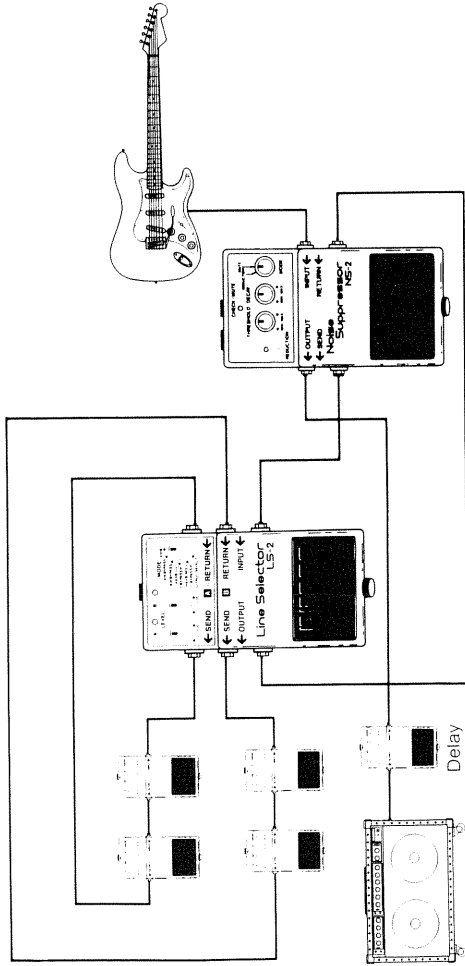

A↔B Mode

You can select one of two settings (for solos or backing).

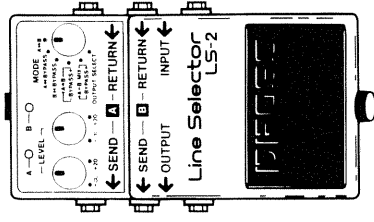
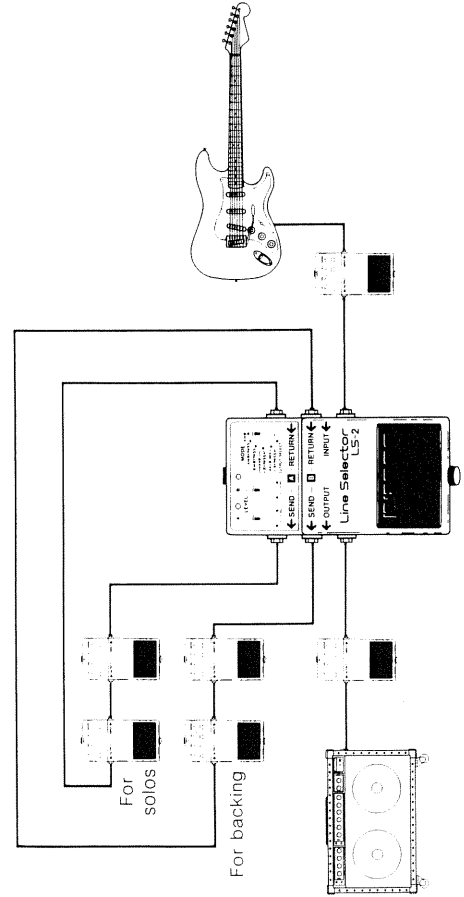

Printed in Taiwan '91-10-D3-11C

A↔B Mode

You can select output Effect [A] or Tuner [B].
(Rotate Level Control Knob B completely counterclockwise.)

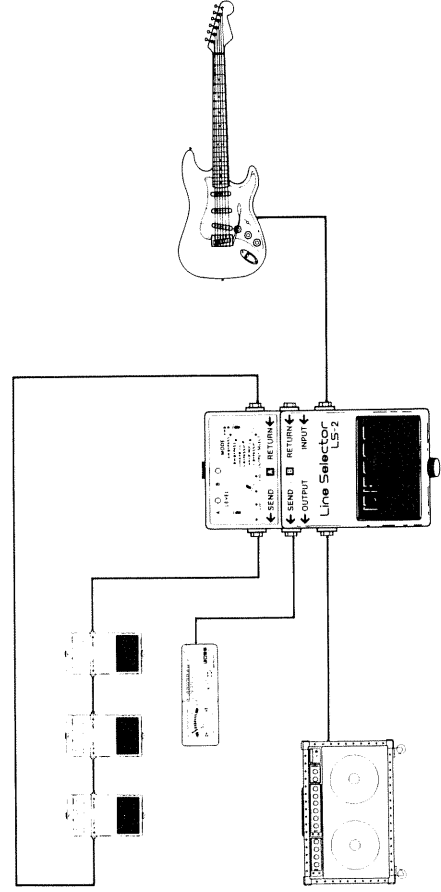

A ↔ B Mode

You can set the Level Control Knobs differently and select one of two volume levels.

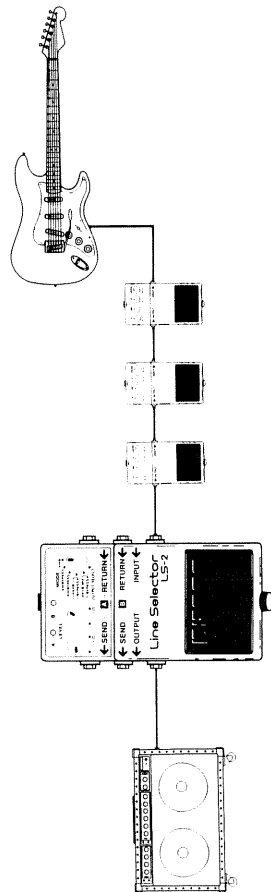

A ↔ B Mode

You can select one of two kinds of distortion.
(Set the Level Control Knobs and choose the desired distortion by selecting a different output level.)

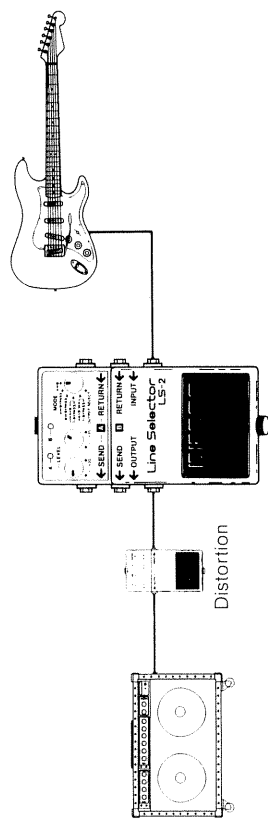

A ↔ B Mode

You can select one of two amplifiers.
(The Level Control Knobs will not function.)

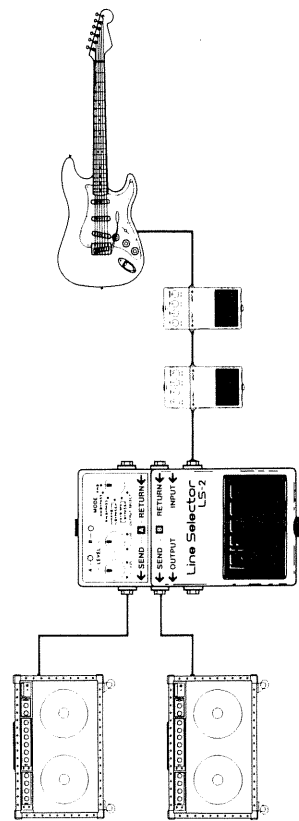

A ↔ B Mode

You can select one of two instruments.
(Be sure to plug into the Input Jack.)

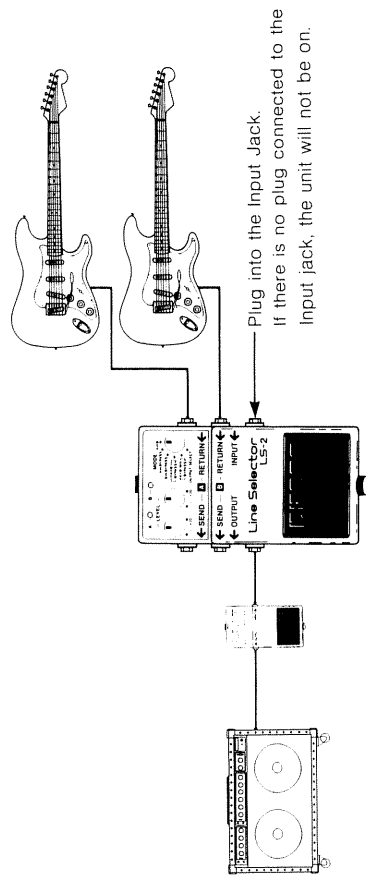

A ↔ BYPASS Mode

You can select one of two settings (for solos or rhythm).

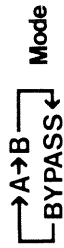
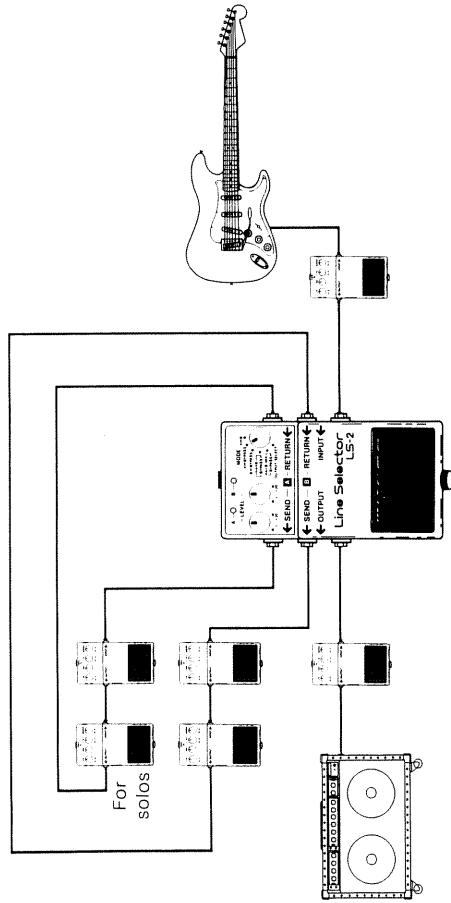

You can select one of three settings (for solos, backing or rhythm).

B ↔ BYPASS Mode

You can select one of two settings (for backing or rhythm).

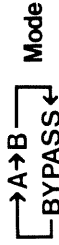
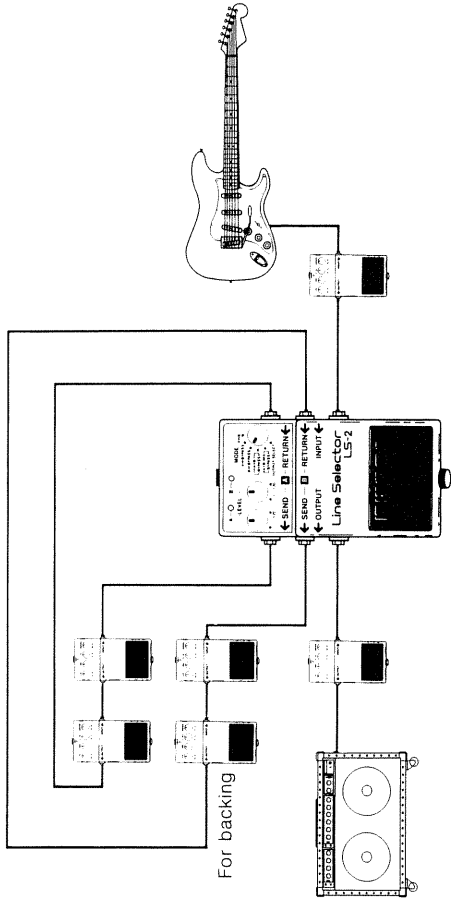

You can select one of three instruments.
 (The Level Control Knob for the instrument connected to the Input Jack will not function.)

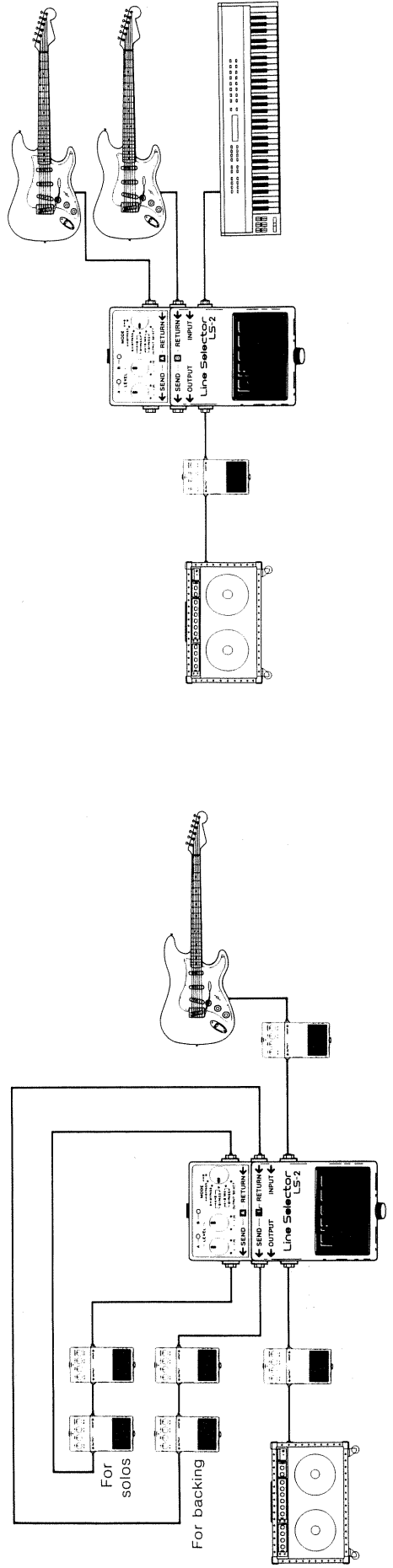

→ A+B MIX ←
← BYPASS → Mode

You can mix two settings (for solos and backing) to create a new effect.

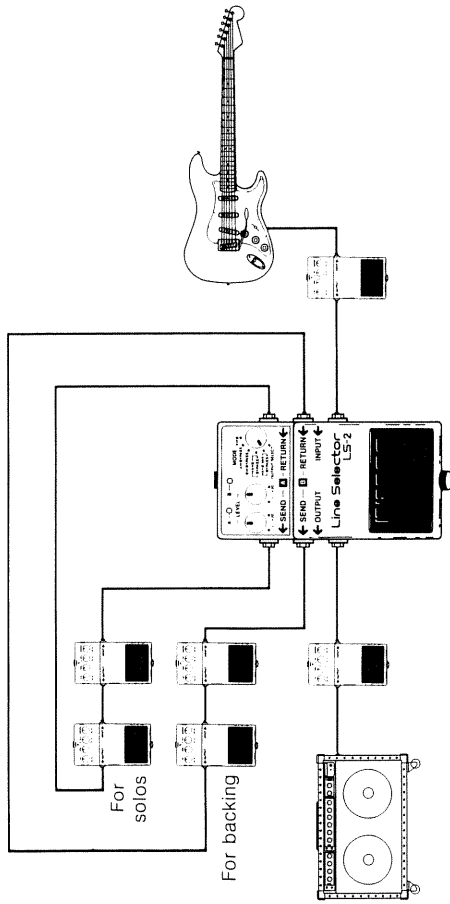

→ A+B MIX ←
← BYPASS → Mode

You can use the LS-2 as a 2 channel mixer.
(Be sure to plug into the Input Jack.)

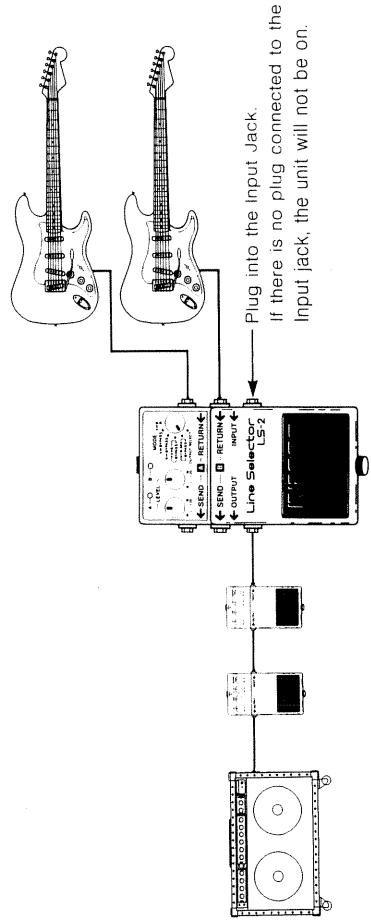

→ A+B MIX ←
← BYPASS → Mode

You can mix effect and straight sounds to create a new effect.

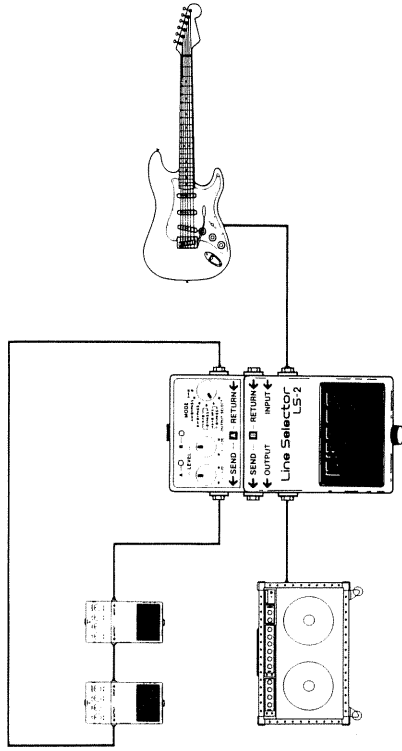

OUTPUT SELECT Mode

You can select one of three amplifiers.
(The Level Control Knobs will not function.)

